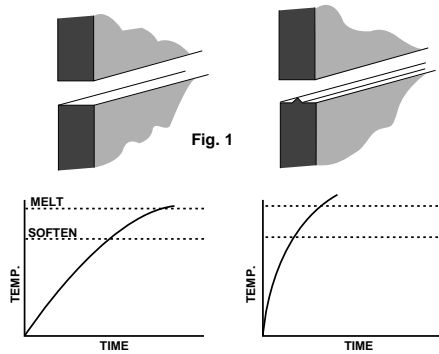
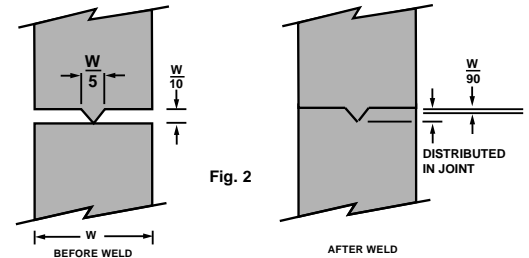

**Figure 1.** The diagrams show time temperature curves for a common butt joint and more ideal joint incorporating an energy director. This modified joint permits rapid welding while achieving maximum strength. The material within the director becomes the sealant which is spread throughout the joint area as indicated below.



**Figure 2.** Shows a simple butt joint modified with energy directors showing desired proportions before weld and indicating the resultant flow of material. Parts should be dimensioned to allow for the dissipation of the material from the energy director throughout the joint area as illustrated.



**Figure 3.** Illustrates a step joint used where a weld bead on the side would be objectionable. This joint is usually much stronger than a butt joint, since material flows into the clearance necessary for a slip fit, establishing a seal that provides strength in shear as well as tension.

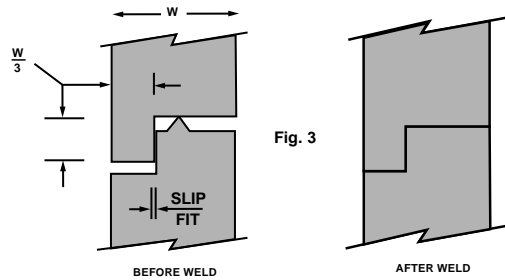

**Figure 4.** A tongue and groove joint usually has the capability of providing greatest strength. The need to maintain clearance on both sides of the tongue, however, makes this more difficult to mold. Draft angles can be modified concurrently with good molding practices, but interference between elements must be avoided.

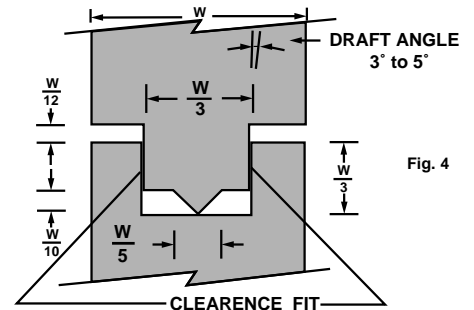

**Figure 5.** Illustrates basic joint variations suitable for ultrasonic welding. These are suggested guidelines for typical joint proportions. Specific applications may require slight modification. Practical considerations suggest a minimum height of .005" for the energy director. Where height greater than .020" is indicated, two or more directors should be provided with the sum of heights equalling the formula dimensions.

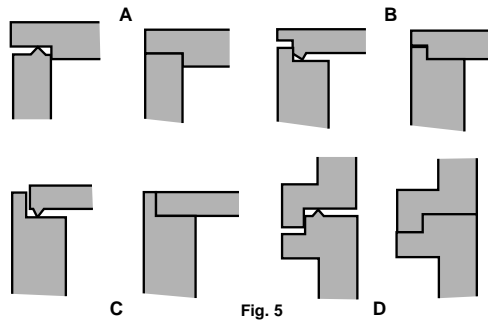

**Note:** When the interference joint is used, weld strength of crystalline materials approaches 95% of parent material strength, as opposed to 40-70% when energy director is used. The interference joint permits interaction between the two surfaces during the entire melt cycle by exposing more and more surface area as the two surface planes interfere under ultrasonic and clamp force.

Good fixturing should be used when the interference joint is utilized as the outer walls of the part may flex or distort if not contained by the nest.

**Figure 6.** Shows the interference joint used when a hermetic joint is needed for the crystalline thermoplastics (nylon, acetal, polyethylene, polypropylene). Since crystalline resins (such as acetal and nylon) have a tendency of being watery in the motion state, the adjoining surfaces remain cool when the energy director has become molten, resulting in little or no interaction of melted and unmelted surfaces. **See Note**

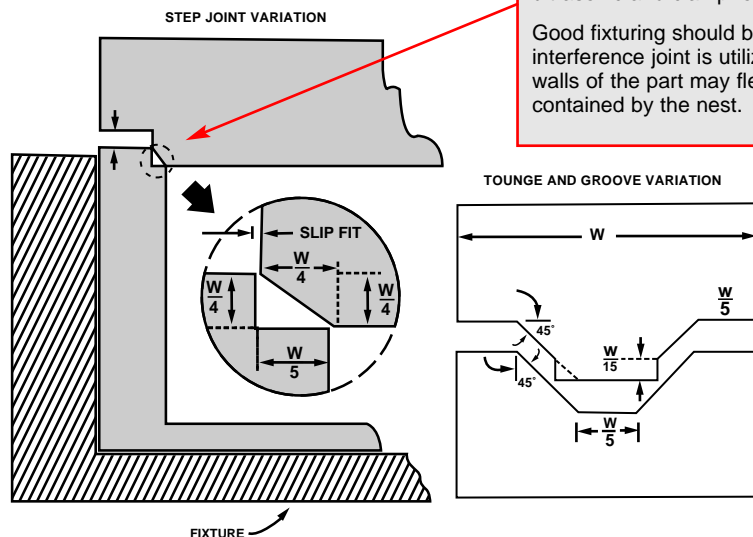

Fig. 6

## INSERTING METAL INTO PLASTIC

For ultrasonic insertion a hole is premolded in the plastic slightly smaller in diameter than the insert it is to receive. Such a hole provides a certain degree of interference-fit and guides the insert into place. For a final interlocking assembly, the metal insert is usually knurled, undercut, or shaped to resist the loads imposed on the finished assembly as pressure is applied.

Ultrasonic vibrations travel through the driven part until they meet the joining area between metal and plastic. At this joint (or interface) the energy of the ultrasonic vibrations is released as heat. The intensity of heat created by the vibration between the plastic and the metal is sufficient to melt the plastic momentarily, permitting the inserts to be driven into place.

Ultrasonic exposure time is usually less than one second, but during this brief contact the plastic reforms itself around knurls, flutes, undercuts, or threads to encapsulate the insert.

**EXAMPLE** A typical assembly consisting of a knob of impact styrene and a steel insert as shown (See Figure 1). If a knob of this type is used as a locking device, it must withstand torque-loading as it is tightened on a threaded rod. It must also withstand axial shear forces as pressure is brought to bear against both plastic and metal insert surfaces.

**DESIGN REQUIREMENTS** Insert/hole design will vary with each application, but a sufficient volume of plastic must always be displaced to fill voids created by knurled and undercut areas of the insert. A slight excess of molten material can usually be tolerated while insufficient interference may result in less than required strength.

**Figure 1.** Shows the relationship of dimensions between a typical undercut insert and the diameter of the premolded hole. For tapered inserts, the hole should also be tapered, as shown in Figure 2. This configuration permits accurate positioning of the insert and reduces installation time. The choice of contacting the plastic or metal surface with the horn will depend upon the configuration of the part, and the ability of the assembly to accept the required vibratory intensity.

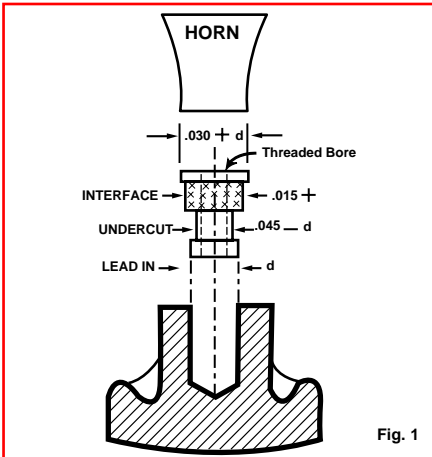

Fig. 1

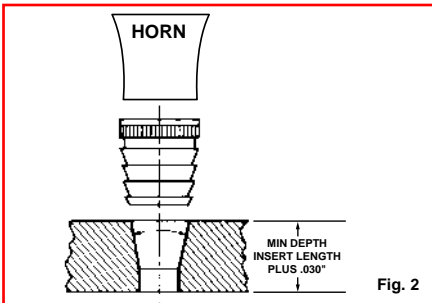

Fig. 2

## STAKING

**GENERAL** As with ultrasonic welding and inserting, ultrasonic staking employs the same principles of creating localized heat through the application of high-frequency vibrations. Many staking applications involve the assembly of metal and plastic components.

**EXAMPLE** In staking, a hole in the metal receives a plastic stud. Ultrasonic staking requires the release of vibratory energy only at the surface of the plastic stud; therefore, the contact area between horn and plastic must be kept as small as possible (Figure 3). The horn is usually contoured to meet the specific requirements of the application. With the introduction of ultrasonic vibrations, the stud melts and reforms to create a locking head over the metal.

**DESIGN REQUIREMENTS** There are two head-forms that will satisfy the requirements of a majority of applications (Figure 4). The first, generally considered standard, produces a head having twice the diameter of the original stud, with the height 1/2 the stud diameter. The second, referred to as a low-profile head, has a head diameter 1 1/2 times the stud diameter, with a head height 1/4 the size of the head diameter. In addition when a conical stud can be used it is the best choice for filled materials. When appearance is not important, a knurled profile can be an excellent choice.

**SET-UP** Unlike ultrasonic plastics welding, staking requires that out-of-phase vibrations be generated between the horn and plastic surfaces. Light, initial contact pressure is therefore a requirement for out-of-phase vibratory activity within the limited contact area as shown in Figure 3. It is the progressive melting of plastic under continuous, but light pressure, that forms the head. Adjustment of the flow-control valve and trigger switch may be required to reduce pressure to the desired level.

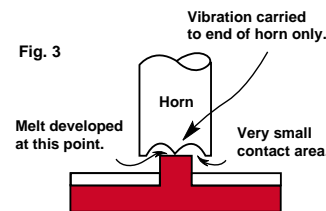

Fig. 3

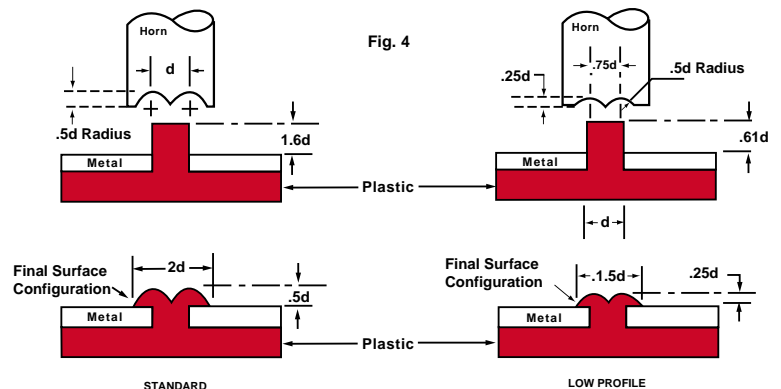

Fig. 4

Head Form	Stud Diam.	Head Diam.	Head Height.	Center-Center Diam.	Stud Height Above Part Before Heading
Standard	d	2d	.5d	d	1.6d
Low Profile	d	1.5d	.25d	1.5d	0.6d

# ULTRASONIC WELDING CHARACTERISTICS AND COMPATIBILITY OF THERMOPLASTICS

Most commonly used injection-molded materials can be ultrasonically welded without the use of solvents, heat or adhesives. Weldability of these materials depends on their melting temperatures, modulus of elasticity, impact resistance, coefficient of friction, and thermal conductivity. Generally, the more rigid the plastic, the easier it is to weld. Low modulus materials such as polyethylene can often be welded provided the horn can be positioned close to the joint area.

In staking, the opposite is usually true. The softer the plastic, the easier it is to stake. However, good results can be achieved with most plastics when the right amplitude and force combination is used.

**Table 1** indicates relative weldability characteristics for the more common thermoplastics. **Table 2** shows the compatibility for ultrasonic welding of dissimilar materials.

**TABLE I CHARACTERISTICS\*\***

Material	% Weld strength*	Spot weld	Staking and inserting	Swaging	Welding	
					Near field†	Far field†
<b>General-purpose plastics</b>						
ABS	95-100+	E	E	G	E	G
Polystyrene unfilled	95-100+	E	E	F	E	E
Structural foam	90-100a	E	E	F	G	P
Rubber modified	95-100	E	E	G	E	G-P
Glass filled (up to 30%)	95-100+	E	E	F	E	E
SAN	95-100+	E	E	F	E	E
<b>Engineering plastics</b>						
ABS	95-100+	E	E	G	E	G
ABS/polycarbonate alloy (Cycloy 800)	95-100+b	E	E	G	E	G
ABS/PVC alloy (Cycovin)	95-100+	E	E	G	G	F
Acetal	65-70c	G	E	P	G	G
Acrylics	95-100+d	G	E	P	E	G
Acrylic multipolymer (XT-polymer)	95-100	E	E	G	E	G
Acrylic/PVC alloy (Kydex)	95-100+	E	E	G	G	F
ASA	95-100+	E	E	G	E	G
Modified phenylene oxide (Noryl)	95-100+	E	E	F-P	G	E-G
Nylon	90-100+b	E	E	F-P	G	F
Phenoxy	90-100	G	E	G	G	G-F
Polycarbonate	95-100+b	E	E	G-F	E	E
Polyimide	80-90	F	G	P	G	F
Polyphenylene oxide	95-100+	E	G	F-P	G	G-F
Polysulfone	95-100+b	E	E	F	G	G-F
<b>High-volume, low-cost applications</b>						
Butyrates	90-100	G	G-F	G	P	P
Cellulosics	90-100	G	G-F	G	P	P
Polyethylene	90-100	E	E	G	G-P	F-P
Polypropylene	90-100	E	E	G	G-P	F-P
Structural foam	85-100	E	E	F	G	F-P
Vinyls	40-100	G	G-F	G	F-P	F-P

Code: E= Excellent, G= Good, F= Fair, P= Poor  
 \*Weld strengths are based on destructive testing  
 100+% results indicate that parent material  
 a=High-density foams weld best.  
 of plastic part gave way while weld remained intact.  
 b=moisture will inhibit welds.  
 †Near field welding refers to joint 1/4 in. or less from area of horn contact; far field welding to joint more than 1/4 in. from contact area.  
 c=Requires high energy and long ultrasonic exposure because of low coefficient of friction.  
 d=Cast grades are more difficult to weld due to high molecular weight

**TABLE 2**

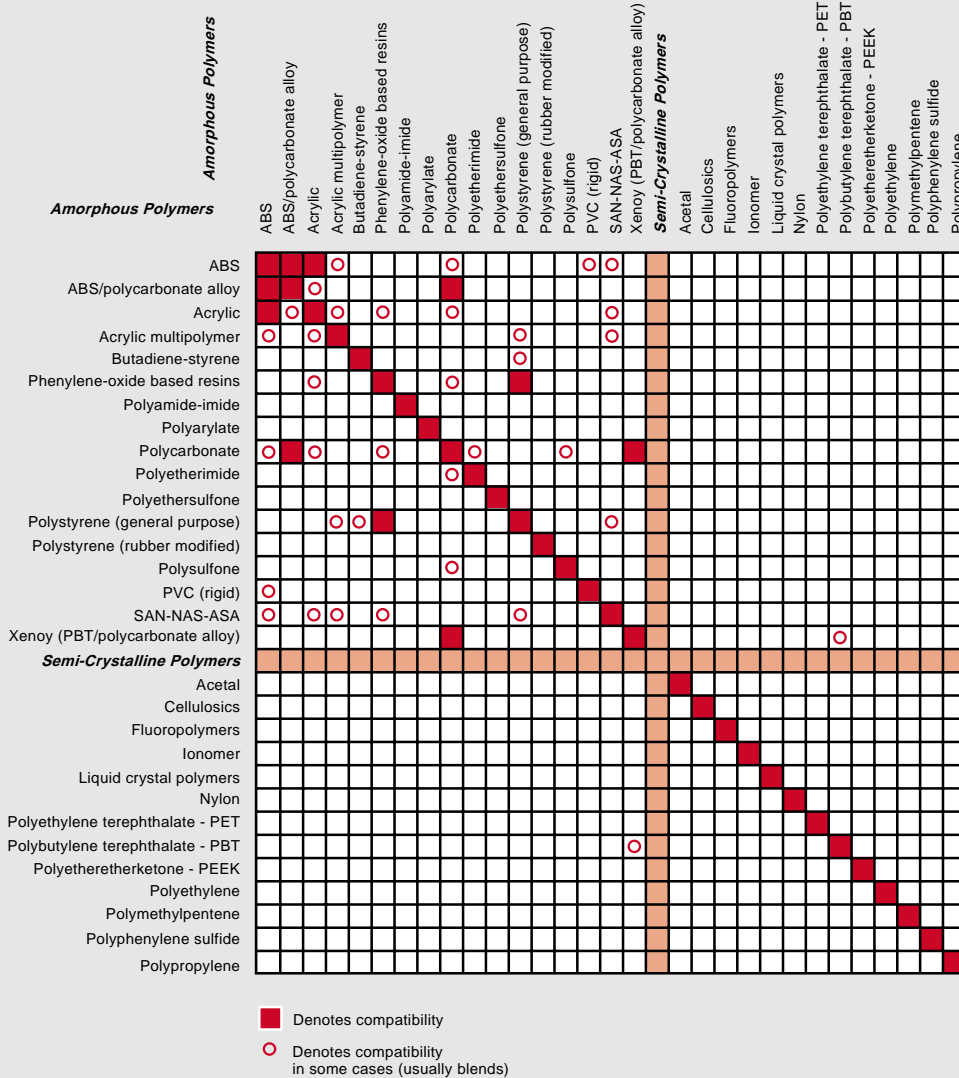

The success of welding and staking of plastics or inserting metal into plastic depends upon the proper amplitude of the horn tip. Since it may be impossible to design the correct amplitude into the horn initially because of its shape, booster horns are necessary to either increase or decrease the amplitude to produce the proper degree of melt or flow in the plastic part. The choice of plastic, the shape of the part, and the nature of the work to be performed all determines what the optimum horn amplitude should be.

Six amplitude-modifying booster horns are available: three for increasing amplitude and three for decreasing amplitude. Each horn is anodized with the coded color for easy identification.

Amplitude Increasing Ratio	Color	Coupling Bar* Ratio	Color	Amplitude Decreasing Ratio	Color
1 to 1.5	Gold	1 to 1	Green	1 to .6	Purple
1 to 2.0	Silver			1 to .5	Blue
1 to 2.5	Black			1 to .4	Red

Higher ratio boosters are available on special order but require approval for purchase from our engineering department. It should be noted that each horn has a limit to which its amplitude can be increased without fracturing the horn.

**Figure 1** Is a graph showing how the amplitude of a typical horn can be changed by using booster horns.

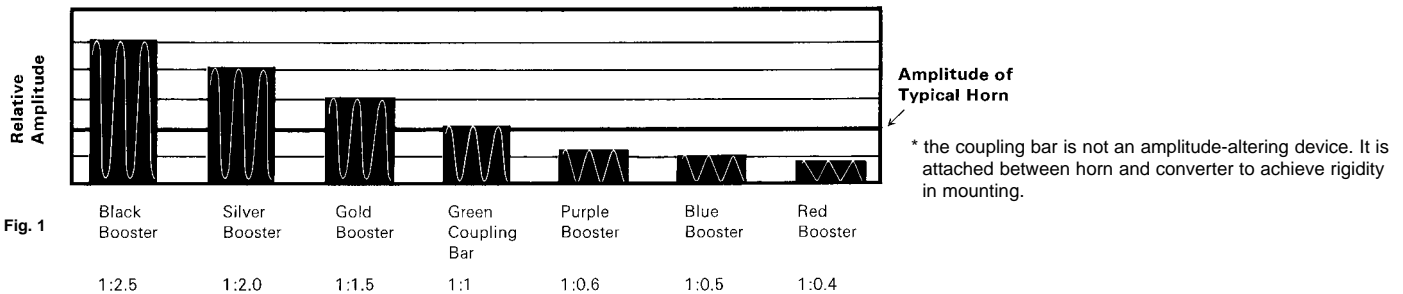

**Figure 2** Further illustrates how a set of three amplitude-increasing boosters can change the pressure requirements of a typical exponential horn and power supply combination. With lower amplitude there is a greater force capability. For purpose of illustration, a high-amplitude horn might be compared to third gear in a car which produces higher speed and low torque. Conversely a low-amplitude horn — similar to first gear which produces low speed and high torque — has tremendous force capabilities and will vibrate under hundreds of pounds of load. It is relatively easy to “stall” a high-amplitude horn by operating it under high pressure conditions, just as it would be easy to stall a car motor starting up a steep hill in third gear. Each horn-booster combination must be tailored to the specific application for optimum performance.

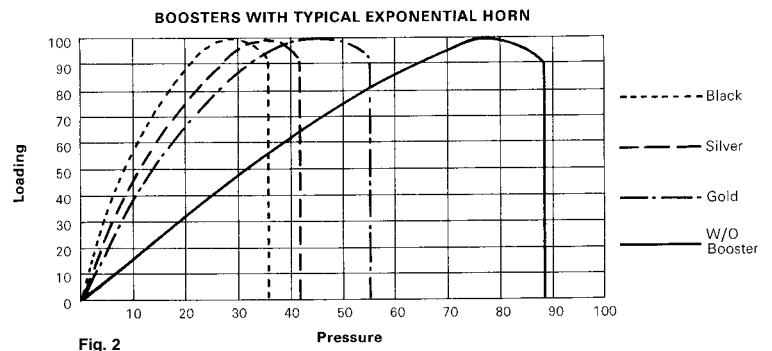

**The conditions which suggest the need for altering the amplitude of a horn are listed below.**

**Increase Amplitude When:**

1. There is difficulty getting energy to joint resulting in a poor or slow weld.
2. Energy is passing through joint (vibration can be felt in nested part; part may show marking from nest).
3. There is difficulty getting proper loading, or pressure required is beyond range of stand.
4. Diaphragming occurs. (Burnout of circular parts.)
5. If staking, melting occurs at base of stud instead of at surface.
6. Marking of parts occurs because of excessively long weld times.

**Decrease Amplitude When:**

1. System will not start or starts with difficulty.
2. System stalls with low pressure.
3. Excessive no load readings occur on power supply.
4. Going from solid to tapped horn.
5. Marking of parts occurs. High pressure provides better coupling of vibration into plastic.
6. Plastic parts are shattered or metal inserts fracture.
7. Excessive heat builds up near nodal area in horn.
8. Diaphragming occurs.